

# Self-gripping gasketing

## PROGRAM 1011

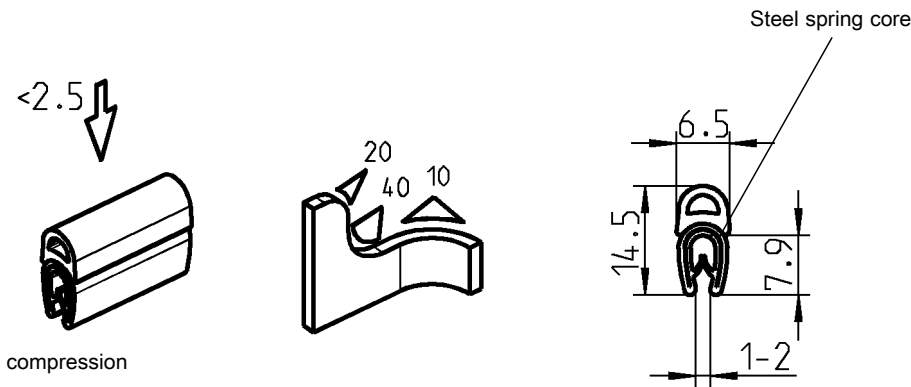

compression

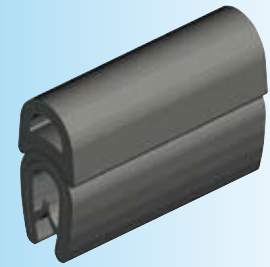

Sponge rubber (EPDM) black (clamping profile PVC 70° ± 5 Shore A)

1011-24

**RU** <sup>®</sup> **US** \*

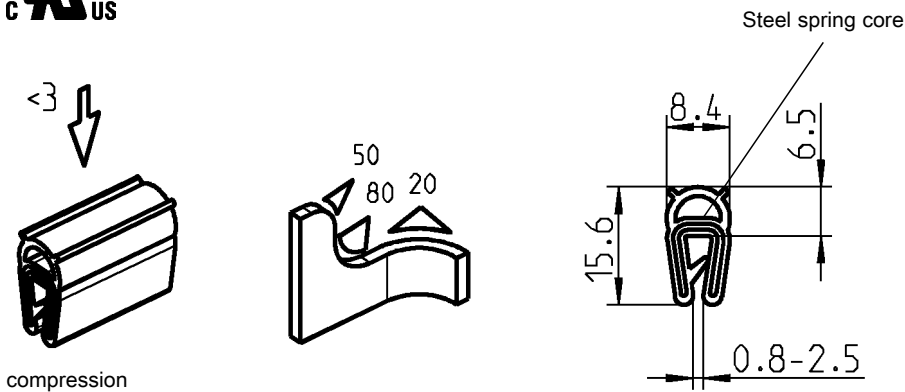

compression

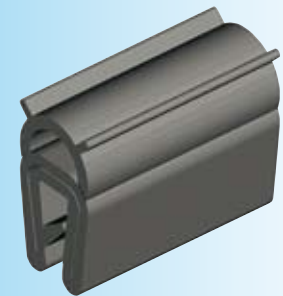

Material for gasket depends upon choice

Sponge-rubber (EPDM) black (gasket EPDM 65° ± 5 Shore)	1011-10*
Foam rubber (NBR) black (gasket NBR 60° ± 5 Shore A)	1011-50

**RU** <sup>®</sup> **US** \*

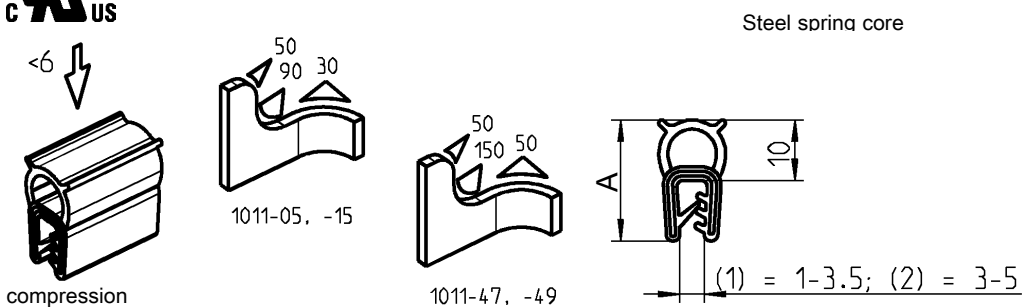

compression

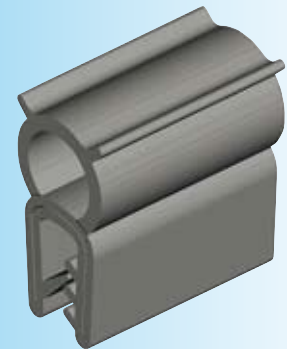

Material for gasket depends upon choice

	A	
Sponge-rubber (EPDM) black (gasket EPDM 65° ± 5 Shore)	20	1011-05* (1)
Foam rubber (NBR) black (gasket NBR 60° ± 5 Shore A)	21	1011-15 (1)
Sponge-rubber (EPDM) black (gasket EPDM 65° ± 5 Shore)	21	1011-49 (2)
Foam rubber (NBR) black (gasket NBR 60° ± 5 Shore A)	21	1011-47 (2)

**RU** <sup>®</sup> **US**

UL 50  
UL 50E  
UL 94-HB