









# DIFFERENTIAL PRESSURE TRANSMITTERS

# MEASUREMENT OF DIFFERENTIAL PRESSURE

Measurement of differential pressure is useful in a broad range of applications. It is used in ventilation and air-conditioning technology but also in many areas of air handling process technology. The table below shows a number of these. You can find more information about pressure sensor technology on p. 6.

halstrup-walcher offers a wide range of products for stationary measurement of differential pressure.

	PUC24	PUC28(K)	P26	P34	P29	PU/PI/PIZ	P82R(M)	PS27	REG21
Details on	p. 24	p. 25	p. 26	p. 27	p. 28	p. 29	p. 30	p. 31	p. 32
									
<b>Application</b>	Process monitoring for clean-rooms (Pa, °C, % rH), with stainless steel front	Process monitoring panel (optional: with calibration port) (Pa, °C, % rH), aluminium, anodised	High precision, scalable differential pressure transmitter	Measuring transmitter with very small dimensions – ideal for the control cabinet	Like P26, for natural gas	For standard applications. PIZ: PI in two wire technology	Square-root standard differential pressure transmitter	A basic sensor for simple applications	Measurement and regulation of pressure
<b>Housing installation</b>	Installed in wall (panel)		Mounted on a wall/top-hat rail						Rack
<b>Max. measurement range</b>	± 250 Pa		± 100 kPa			± 100 kPa	± 20 kPa	± 100 kPa	
<b>Min. measurement range</b>	± 100 Pa		± 10 Pa		± 250 Pa	± 50 Pa	± 100 Pa	± 50 Pa	
<b>Degree of measurement uncertainty</b>	0.5 % <sup>1)</sup> (standard)	0.5 % <sup>1)</sup> (standard)	0.2 % of the scaled range (40.. 100 % of max. value) <sup>2)</sup> (optional) 0.5 % of the scaled range (40.. 100 % of max. value) <sup>2)</sup> (standard)		0.2 % <sup>1)</sup> (optional) 0.5 % <sup>1)</sup> (standard)	0.2 % <sup>1)</sup> <sup>2)</sup> <sup>3)</sup> 0.5 % <sup>1)</sup> <sup>2)</sup> 1 % <sup>1)</sup>	1 % <sup>1)</sup>	2 % (≥ 100 Pa) or 3 % (for 50 Pa) of the set value	0.5 % <sup>1)</sup> <sup>2)</sup> 1 % <sup>1)</sup>
<b>Square-root (volume flow)</b>	-	-	✓	✓ <sup>4)</sup>	✓	-	✓	-	-
<b>Display</b>	✓	✓	optional	-	optional	optional	optional	optional	✓

<sup>1)</sup> max. value of upper range value

<sup>2)</sup> but not less than 0.3 Pa

<sup>3)</sup> for measurement ranges ≥ 250 Pa only

<sup>4)</sup> optionally with stat. pressure sensor and temperature analogue input for compensation

## ACCESSORIES

### Certificates

DAkkS calibration certificate (German)

DAkkS calibration certificate (English)

ISO factory calibration certificate

### Order no.

9601.0003

9601.0004

9601.0002

### Connecting components

Silicone tubing ID 5 mm, OD 9 mm, red 9601.0160 (please state length required)

Silicone tubing ID 5 mm, OD 9 mm, blue 9601.0161 (please state length required)

Norprene tubing 9061.0132 (please state length required)

Y-piece for tubing 9601.0171

### Pressure ports

We can supply a wide range of customer-specific pressure ports, e.g. various cutting ring couplings or hose connectors.

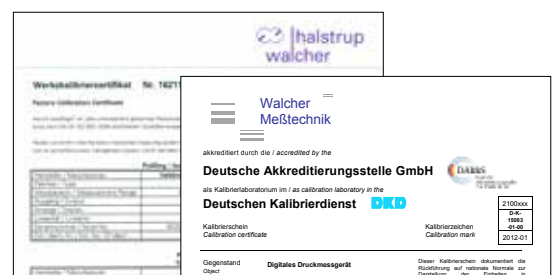

# MEASUREMENT OF DIFFERENTIAL PRESSURE AND REGULATION OF PRESSURE

## ... IN CLEANROOMS

In cleanrooms, it is vital to prevent contaminated air flowing in from corridors or areas with lower cleanroom classifications. This can be achieved by **maintaining a continuous overpressure** inside the cleanroom. The heart of this system is a high-precision differential pressure transmitter operating in the low Pascal range

- for installation in a wall (panel), (e.g. PUC, see p. 24 and p. 25)
- for installation in a control cabinet (top hat rail) (e.g. P26, see. p. 26)
- for mounting on a wall (e.g. P26, see. p. 26)

The standard ISO 14644 requires continuous monitoring and regulation of pressure for all cleanrooms. In addition, spot checks must be performed at regular intervals.

- use of the KAL portable, high precision calibration and measurement device (see p. 44 and 45)

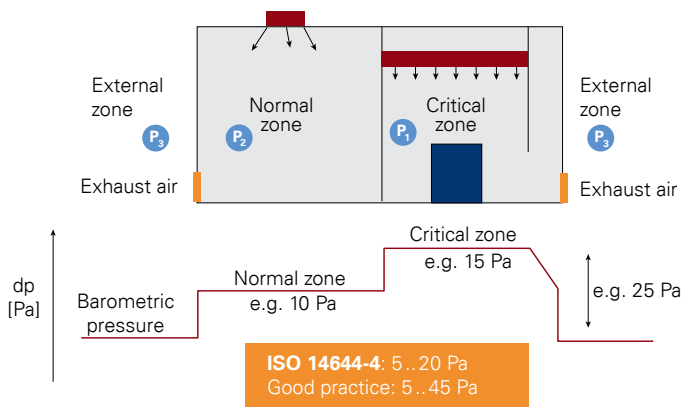
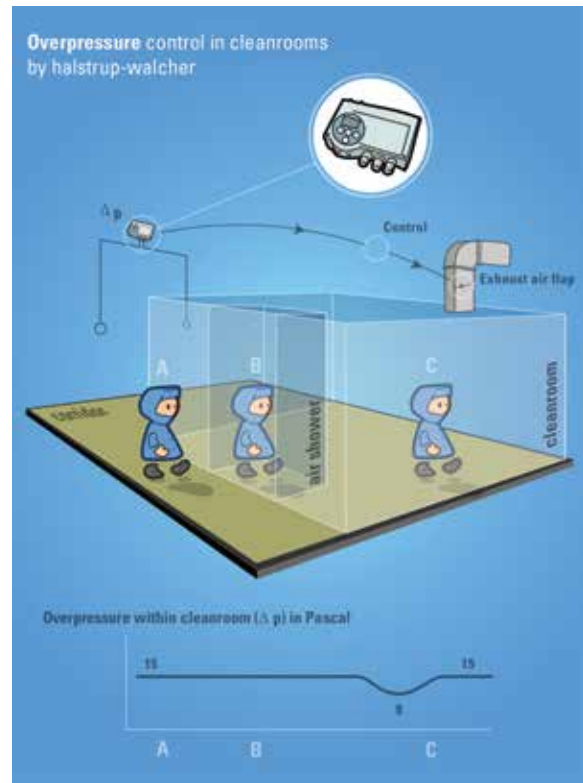

## ... IN HOSPITALS

Excluding air that contains bacteria can be a matter of life and death, especially in hospitals, e.g. operating theatres. Here, too, this is achieved by ensuring a constant **overpressure** in the room that prevents contaminated air entering it from surrounding areas.

The opposite applies to isolation wards, which are used to prevent the spread of epidemics. In this case, the room must be kept at a constant **underpressure** relative to its surroundings in order to prevent bacteria/viruses escaping.

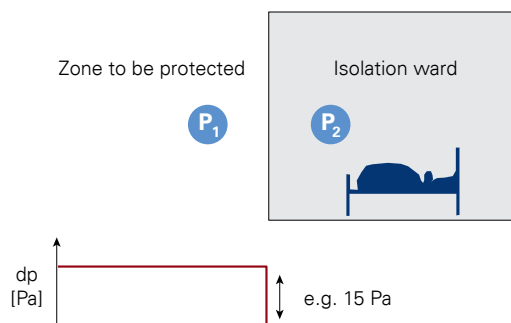

# MEASUREMENT OF DIFFERENTIAL PRESSURE AND REGULATION OF PRESSURE

... IN FILLING MACHINES AND HYGIENIC PLANTS

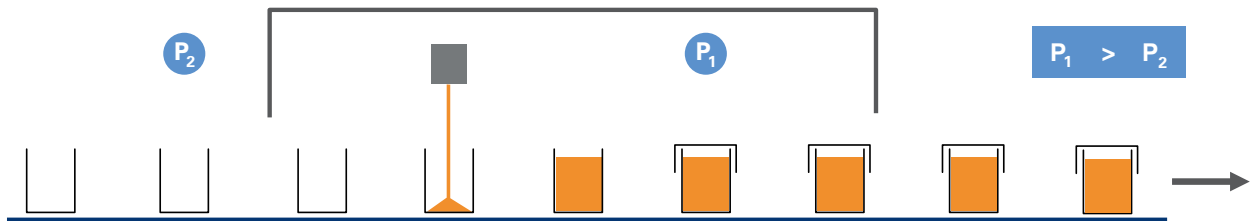

Hygiene and bacteria-free environments are key requirements in both the pharmaceutical and food processing industries. This is achieved through selecting the appropriate materials and time-consuming cleaning processes. But what happens if the goods being protected come into contact with the surrounding air? If this air has not been correctly processed, it will transport microbes and other contaminants (oil aerosols, particles etc.) directly to the endangered product.

For larger hygienic production plants, the construction of whole cleanrooms is a viable option. However, this approach may be inefficient if only a small, enclosable hygienic area is required. The solution to this problem was the development of "mini-environments" – isolated, hygienic areas. These ensure that no microbes or contaminants are able to penetrate the protected area.

Measurement and regulation of differential pressure are the keys to maintaining a constant and safe **overpressure** within the mini-environment. Long-term stability is critical in order to prevent unplanned decreases in pressure over time. halstrup-walcher is a specialist in this type of application and offers

- for mounting on walls or top-hat rails: P26 (see p. 26)
- for mounting in walls (panel version): PUC24 or PUC28K (see p. 24/25)



The **pressure** in the filling room must be **higher** than that of the surrounding areas or particles/oil etc. may enter the zone in which the product is being handled.

Measurement ranges	± 100 Pa or ± 250 Pa freely scalable within this range
Margin of error	0.5 % of max. value
Temperature coefficient span	0.03 % of max. value/K (10..50 °C)
Temperature coefficient zero point	± 0 % (cyclical zero-point correction)
Overload capacity	200 x
Medium	Air, all non-aggressive gases
Max. system pressure	10 kPa
Sensor response time	25 ms
Time constants	25 ms..40 s (adjustable)
Input signal humidity/temperature module (galvanically separated)	0..10 V, R <sub>i</sub> = 470 kΩ 0/4 ..20 mA, R <sub>i</sub> = 50 Ω adjustable
Operating temperature	10..50 °C
Storage temperature	-10..70 °C
Power consumption	approx. 7 VA
Weight	approx. 1 kg
Pressure ports	for tubing NW 3..6 mm
Protection class	IP65 (recessed in the wall)
Certificates	CE

<b>Supply voltage</b>
24 VDC, ± 10 % smoothed

<b>Output</b>
0..10 V (R <sub>i</sub> > 2 kΩ) 0/4 ..20 mA (R <sub>i</sub> < 500 Ω) adjustable
2 contact points, 6 A, 230 VAC, may be configured as desired within this pressure range

<b>Measurement range</b>	<b>A</b>
± 100 Pa	0
± 250 Pa	1

<b>Data interface</b>	<b>B</b>
None	0
PROFIBUS DP (optional)	DP
RS232 (optional)	2

<b>Bus connection</b>	<b>C</b>
None	0
9-pin Sub-D flush type connector <sup>1)</sup>	D
Sub-D plug with 150 mm cable	DK
Round pin connector M 12 with 150 mm cable	RK

<sup>1)</sup> not suitable for wall thicknesses greater than 5 mm

<b>Order code</b>	<b>A</b>	<b>B</b>	<b>C</b>
<b>PUC24</b>	-	-	-

Can be pre-set on request:  
Time constant, relay parameter, analogue output,  
deactivation of the cyclic zeroing (only for PROFIBUS DP)



**Features**

- Cleanroom panel (stainless steel) for displaying air-conditioning data
- Integrated, high precision measurement of differential pressure
- % rH/°C pressure transmitter, switchable (independent of manufacturer)
- Optimum cleanroom design (TU Munich/Weihenstephan)
- Solvent resistant stainless steel surface
- 3 analog outputs, optional digital interface
- Acoustic alarm when the threshold value is exceeded, acknowledgement via key
- Optical alarm signal if critical values are exceeded; the display values are shown cyclically inversed/normal
- Bilingual menu (German/English) (others on request)
- Two contact points (6 A/230 VAC)
- Two adjustable limit switches permit the connection of signalling devices and save additional wiring (optional)

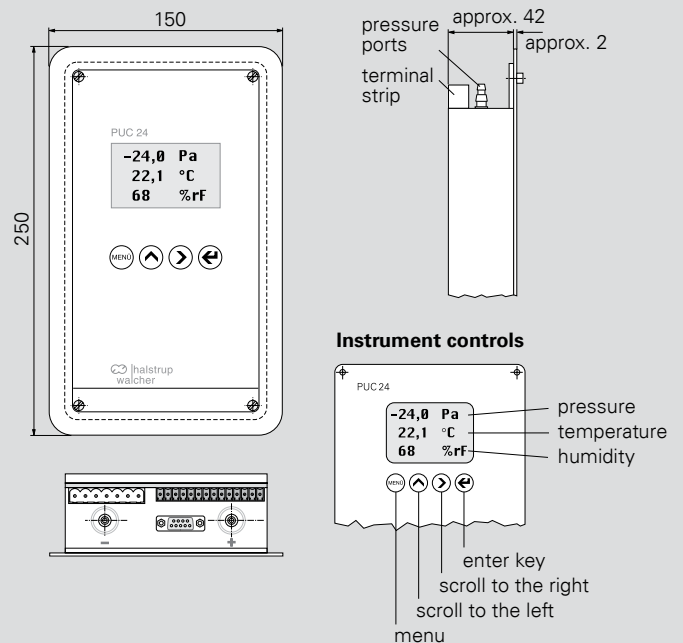



## Features

- Process panel (Aluminium, anodised) for displaying air-conditioning data
- Integrated, high precision measurement of differential pressure
- % rH/°C pressure transmitter, switchable (independent of manufacturer)
- Anodised, aluminium housing with easy-to-clean front surface
- With external calibration ports (*design "K"*), for on-site calibration without disassembly
- 3 analog outputs, optional digital interface
- Acoustic alarm when the threshold value is exceeded, acknowledgement via key
- Optical alarm signal if critical values are exceeded; the display values are shown cyclically inverted/normal
- Bilingual menu (German/English) (others on request)
- Two contact points (6 A/230 VAC)
- Two adjustable limit switches permit the connection of signalling devices and save additional wiring (optional)

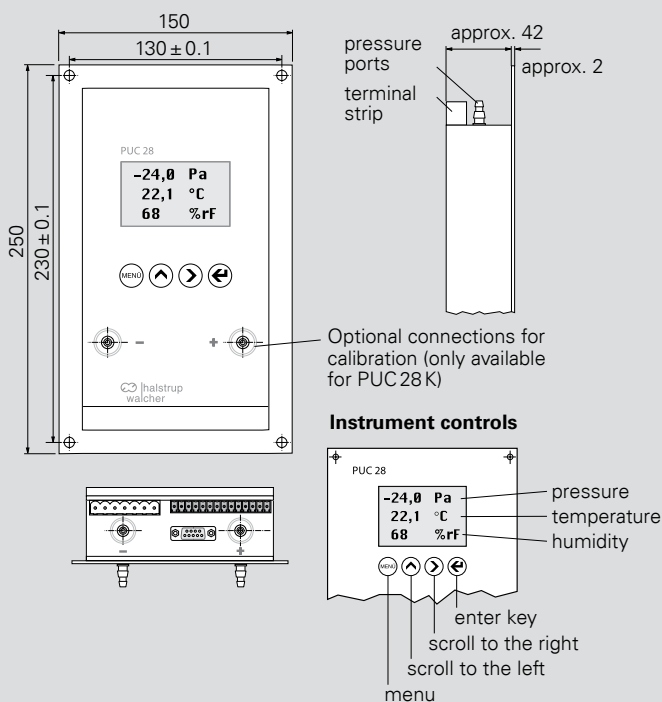

Measurement ranges	± 100 Pa or ± 250 Pa freely scalable within this range
Margin of error	0.5 % of max. value
Temperature coefficient span	0.03 % of max. value/K (10.. 50 °C)
Temperature coefficient zero point	± 0 % (cyclical zero-point correction)
Overload capacity	200 x
Medium	Air, all non-aggressive gases
Max. system pressure	10 kPa
Sensor response time	25 ms
Time constants	25 ms..40 s (adjustable)
Input signal humidity/temperature module (galvanically separated)	0..10 V, R <sub>i</sub> = 470 kΩ 0/4..20 mA, R <sub>i</sub> = 50 Ω adjustable
Operating temperature	10.. 50 °C
Storage temperature	-10..70 °C
Power consumption	approx. 7 VA
Weight	approx. 1 kg
Pressure ports	for tubing NW 3..6 mm
Protection class	IP65 (recessed in the wall)
Certificates	CE

<b>Supply voltage</b>
24 VDC, ± 10 % smoothed

<b>Output</b>
0..10 V (R <sub>i</sub> > 2 kΩ) 0/4..20 mA (R <sub>i</sub> < 500 Ω) adjustable
2 contact points, 6 A, 230 VAC, may be configured as desired within this pressure range

Model	Measurement range	A
PUC 28	± 100 Pa	0
PUC 28	± 250 Pa	1
PUC 28K <sup>1)</sup>	± 100 Pa	K 2
PUC 28K <sup>1)</sup>	± 250 Pa	K 3

<sup>1)</sup> "K": with externally accessible (no disassembly) pressure calibration ports (see photo)

<b>Data interface</b>	<b>B</b>
None	0
PROFIBUS DP (optional)	DP
RS 232 (optional)	2

<b>Bus connection</b>	<b>C</b>
None	0
9-pin Sub-D flush type connector <sup>2)</sup>	D
Sub-D plug with 150 mm cable	DK
Round pin connector M 12 with 150 mm cable	RK

<sup>2)</sup> not suitable for wall thicknesses greater than 5 mm

<b>Order code</b>	<b>A</b>	<b>B</b>	<b>C</b>
<b>PUC28</b>			

**Can be pre-set on request:**  
**Time constant, relay parameter, analogue output, deactivation of the cyclic zeroing (only for PROFIBUS DP)**

Measurement ranges (also ± measurement ranges) others available upon request	10/50/100/250/500 Pa 1/2.5/5/10/20/50/100 kPa freely scalable from 10..100 % within a measurement range
Margin of error (0.3 Pa margin of error for reference)	± 0.2 % or ± 0.5 % of the scaled range (40..100 % of max. value) (min. 0.3 Pa)
Temperature coefficient span	0.03 % of max. value/K (10..50 °C)
Temperature coefficient zero point	± 0 % (cyclical zero-point correction)
Max. system pressure/ Overload capacity	600 kPa for measurement ranges ≥ 2.5 kPa 200 x for measurement ranges < 2.5 kPa
Medium	Air, all non-aggressive gases
Sensor response time	25 ms
Time constants	25 ms..40 s (adjustable)
Operating temperature	10..50 °C
Storage temperature	-10..70 °C
Power consumption	approx. 6 VA
Weight	approx. 750 g
Cable glands	3 x M16
Pressure ports	for tubing NW 6 mm, others available on request
Protection class	IP65, with USB: IP40
Certificates	CE, CSA

Output (linear/ root-extracted) <sup>1)</sup>	A
0..10 V (R <sub>L</sub> ≥ 2 kΩ)	1
0..20 mA (R <sub>L</sub> ≤ 500 Ω)	0
4..20 mA (R <sub>L</sub> ≤ 500 Ω)	4
± 5 V (R <sub>L</sub> ≥ 2 kΩ)	5

<sup>1)</sup> output signals can be configured freely

Power supply	B
24 VAC/DC	24ACDC
24 VAC (with galvanic separation)	24AC
230/115 VAC	230/115

Measurement range	C
Measurement range e.g. 0..10 Pa, -10..50 mbar, ± 100 mmHg (etc.)	

Margin of error	D
± 0.2 % <sup>2)</sup>	2
± 0.5 % <sup>2)</sup>	S

<sup>2)</sup> of the scaled range (40..100 % of max. value) (min. 0.3 Pa)

Display, Keyboard	E
none	0
multi-coloured LCD and keyboard	LC



Contact points	F
none	0
Air meter (see p. 14)	1
2 relays (changeover contacts) max. 230 VAC, 6 A	2

Data interface	G
none	0
USB (data cable supplied)	U0
External zero-point calibration	0X
External zero-point calibration and USB (data cable supplied)	UX

Order code	A	B	C	D	E	F	G
P26	-	-	-	-	-	-	-

Can be pre-set on request:  
Time constant, relay parameter, analogue output root-extracted / linear, deactivation of the cyclic zeroing



**Features**

- High precision differential pressure transmitter for top-hat rail or wall mounting (air-conditioning, cleanroom, process)
- Wide range of units available for pressure and volume flow, also ± measurement ranges
- Scalable measurement ranges and units
- Zero-point calibration prevents zero-point drift
- Built-in valve provides a high level of overpressure protection
- Multilingual menu (German/English/Italian/French)

**Optional**

- Contact points with adjustable switching outputs
- Set the zero-point via the interface
- USB interface (free parameterisation software at [www.halstrup-walcher.com](http://www.halstrup-walcher.com))
- Air meter function (see p. 14)

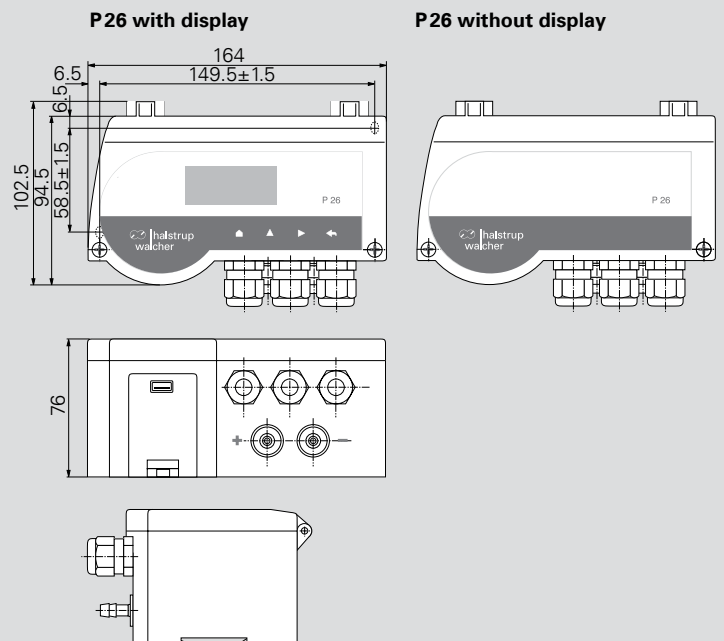



## Features

- Differential pressure transmitter with very small dimensions – ideal for control cabinet installation
- Optionally with temperature analogue input and internal stat. pressure sensor for P-/T-compensated volume flow
- Optionally with relay
- Volume flow can be configured via k-factor, dPmax/Vmax or 20 individual values
- With USB interface: via PC-software (password-protected), scaling, characteristic line form and many other parameters can be set
- Delivery possible already completely integrated into the control cabinet (on request)



## Easy Mounting:

The differential pressure transmitter P34 is particularly developed for space-saving mounting in control cabinets.

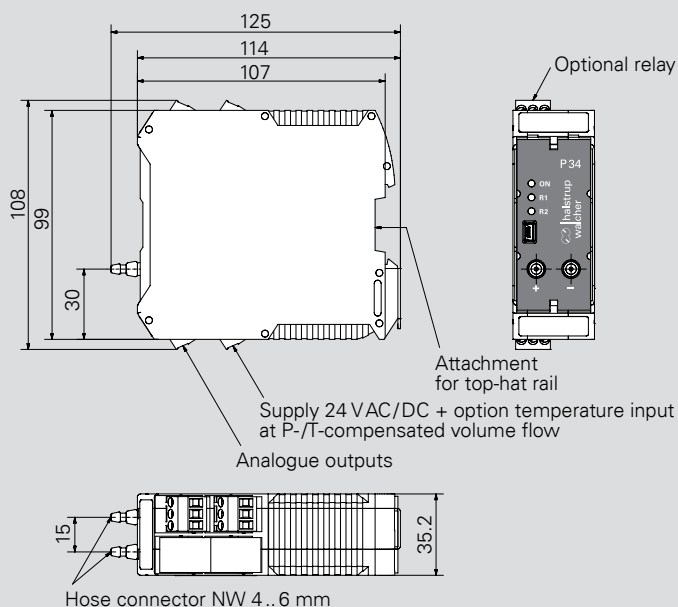

## Measured data differential pressure

Measurement ranges (also ± measurement ranges) others available upon request	10/50/100/250/500 Pa 1/2.5/5/10/20/50/100 kPa freely scalable from 10..100 % within a measurement range
Margin of error (0.3 Pa margin of error for reference)	±0.2 % or ±0.5 % of the scaled range (40..100 % of max. value) (min. 0.3 Pa)
Temperature coefficient span	0.03 % v. E./K (10..50 °C)
Temperature coefficient zero point	±0 % (cyclical zero-point correction)
Max. system pressure/ Overload capacity	400 kPa measurement ranges ≥ 2.5 kPa 200 x measurement ranges < 2.5 kPa
Medium	Air, all non-aggressive gases
Sensor response time	25 ms
Time constants	25 ms..60 s (adjustable)
Operating temperature	10..50 °C
Storage temperature	-10..70 °C
Power consumption	approx. 6 VA
Weight	approx. 450 g
Connections	Screw terminals (connection capacity 0.25..2.5 mm <sup>2</sup> )
USB interface	USB 2.0 Full-Speed Slave (Mini USB)
Pressure ports	for tubing NW 4..6 mm
Protection class	IP20
Certificates	CE

## Measured data for P-/T-compensated volume flow (optional)

Measured range absolute pressure	200 kPa
Accuracy absolute pressure	±2.0 % of max. value
Temperature input	4..20 mA, R <sub>i</sub> = 130 Ω Temperature range freely scalable

## Power supply

24 VAC/DC ± 10 %

Output (linear / root extracted)	A
0..10 V (R <sub>L</sub> ≥ 2 kΩ)	1
0..20 mA (R <sub>L</sub> ≤ 500 Ω)	2
4..20 mA (R <sub>L</sub> ≤ 500 Ω)	3

Measurement range	B
Measurement range e.g. 0..10 Pa, -10..50 mbar, ±100 mmHg (etc.)	

Margin of error	C
± 0.2 % <sup>2)</sup>	2
± 0.5 % <sup>2)</sup>	5

<sup>2)</sup> of the scaled range (40..100 % of max. value) (min. 0.3 Pa)

Contact points	D
none	0
2 relays (changeover contacts) max. 230 VAC, 6 A	2

Application	E
Standard	A
P-/T-compensated volume flow	B

Order code	A	B	C	D	E
P34	-	-	-	-	-

## Can be pre-set on request:

Time constant, relay parameter, analogue output root-extracted / linear, deactivation of the cyclic zeroing



Measurement ranges others available upon request	250/500 Pa 1/2.5/5/10/20/50/100 kPa freely scalable from 10..100 % within a measurement range
Margin of error	±0.2 % of max. value or ±0.5 % of max. value
Temperature coefficient span	0.03 % of max. value/K (10..50 °C)
Temperature coefficient zero point	±0 % (cyclical zero-point correction)
Overload capacity	100 kPa for measurement ranges ≥ 2.5 kPa 200 x for measurement ranges < 2.5 kPa
Medium	Natural gas
Max. system pressure	100 kPa for all measurement ranges
Sensor response time	25 ms
Time constants	25 ms..60 s (adjustable)
Operating temperature	10..50 °C
Storage temperature	-10..70 °C
Power consumption	approx. 6 VA
Weight	approx. 750 g
Cable glands	2 x M 16
Pressure ports	2 x laboratory nozzle DIN 12898
Protection class	IP 65
Certificates	CE, EN1127-1:2007

Output (linear/ root-extracted) <sup>1)</sup>	A
0..10 V ( $R_L \geq 2 \text{ k}\Omega$ )	1
0..20mA ( $R_L \leq 500 \Omega$ )	0
4..20mA ( $R_L \leq 500 \Omega$ )	4
±5 V ( $R_L \geq 2 \text{ k}\Omega$ )	5

Power supply	B
24 VDC	24 DC

<sup>1)</sup> output signals can be configured freely

Measurement range	C
Measurement range e.g. 0..250 Pa, -10..50 mbar, 0..100 mmHg (etc.)	

Margin of error	D
±0.2 % of max. value	2
±0.5 % of max. value	S

Display, keyboard	E
none	0
multi-coloured LCD and keyboard	LC



Tubing connections	F
Standard for tubing NW 5-8 mm	0
Cutting ring coupling 8 mm	S

Order code	A	B	C	D	E	F
P 29						

Can be pre-set on request:  
Time constant, relay parameter, analogue output root-extracted / linear, deactivation of the cyclic zeroing

**TÜV-tested:**

As long as a specified flushing process is observed, special electronic encapsulation safely separates any ignition sources from natural gas.



**Features**

- TÜV-tested differential pressure transmitter for natural gas
- Design changes and technical modifications keep ignition source and gas mixture safely separated (not suitable for Ex-applications)
- Also ± measurement ranges
- Scalable measurement range and display
- For pressure and volume flow measurement
- Zero-point calibration prevents zero-point drift
- Built-in valve provides a high level of overload protection
- Also suitable for top-hat rail mounting
- Multilingual menu (German/English/Italian/French)

P 29 with display

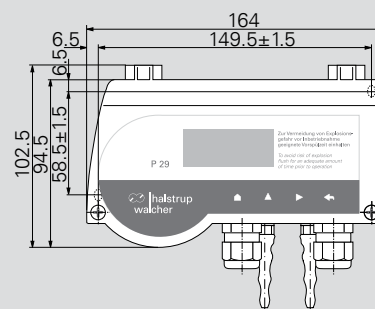

P 29 without display

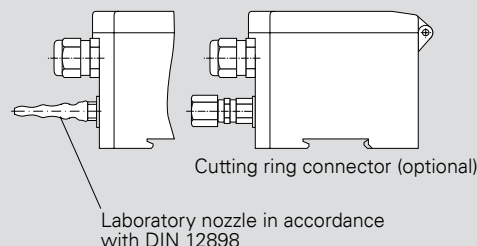
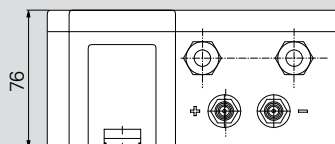
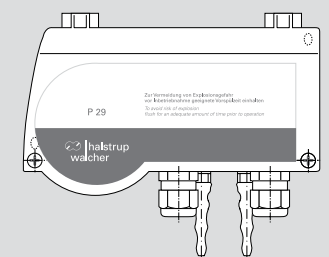



## Features

- Differential pressure transmitter with linear curve for air-conditioning applications
- Also available as a two-wire system ("PIZ" model)
- Also for  $\pm$  measurement ranges and asymmetric measurement ranges
- With optional LCD

### PU/PI with display

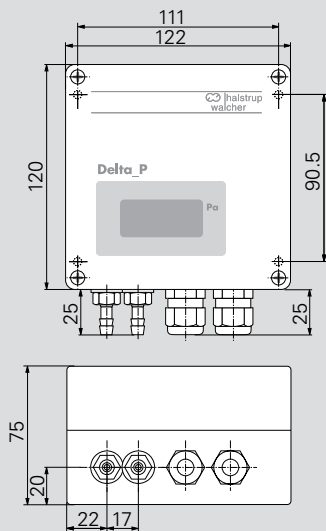

### PU/PI without display

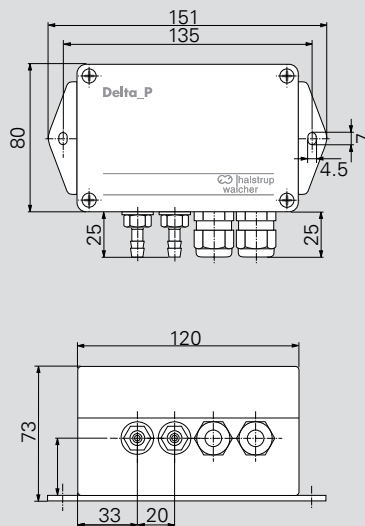

### PIZ with display

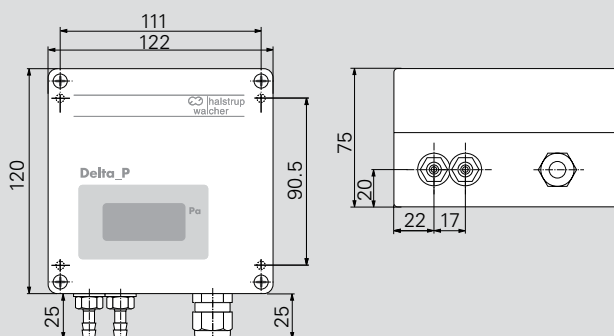

Measurement ranges (also $\pm$ measurement ranges) others available upon request	50/100/250/500 Pa 1/2.5/5/10/20/50/100 kPa
Margin of error (0.3 Pa margin of error for the reference)	0.2 % of max. value only for measurement ranges $\geq$ 250 Pa OR 0.5 % of max. value, min. 0.3 Pa or 1 % of max. value
Temperature coefficient span	0.04 % of max. value/K (10..60°C)
Temperature coefficient zero point	0.04 % of max. value/K (10..60°C)
Zero point stability	0.5 % of max. value/year
Overload capacity	10 x for measurement ranges $\leq$ 20 kPa 2 x for measurement ranges $>$ 20 kPa
Medium	Air, all non-aggressive gases
Max. system pressure	10 kPa for measurement ranges $\leq$ 10 kPa Max. nominal pressure of the sensor for measurement ranges above 10 kPa
Sensor response time	20 ms
Operating temperature	10..60°C
Storage temperature	-10..70°C
Power consumption	PU/PI: approx. 3 VA PIZ: max. 0.6 VA
Weight	approx. 0.8 kg
Cable glands (others available upon request)	PU/PI: 2xPG7 PIZ: 1xPG7
Pressure ports	for tubing NW 6 mm
Protection class	IP65
Certificates	CE, CSA (only for PU/PI)

Output	A
0..10 V ( $R_L \geq 2 \text{ k}\Omega$ )	U
0..20 mA ( $R_L \leq 500 \Omega$ )	I0
4..20 mA ( $R_L \leq 500 \Omega$ )	I4
4..20 mA two-wire ( $R_L \leq 50 [\text{UB (V)} - 10 \text{ (V)}] \Omega$ )	IZ

Measurement range	B
Measurement range e.g. 0..100 Pa, 0..60 mbar, $\pm$ 110 mmHg (etc.)	

Margin of error	C
0.2 % of max. value only for measurement ranges $\geq$ 250 Pa	02
0.5 % of max. value min. 0.3 Pa	05
1 % of max. value	1

Supply voltage	D
24 VDC, +20 % / -15 % <sup>1)</sup>	24D
24 VAC, +6 % / -15 % (50/60 Hz) <sup>1)</sup>	24A
115 VAC, +6 % / -15 % (50/60 Hz) <sup>1)</sup>	115
230 VAC, +6 % / -15 % (50/60 Hz) <sup>1)</sup>	230
10..32 VDC (two-wire system)	PIZ

<sup>1)</sup> not for PIZ

Time constant	E
none	0
1 s	1
2 s	2
5 s	5

LCD	F
none	0
3 ½ digit (see foto)	3
4 ½ digit (only for PU/PI)	4

Order code	A	B	C	D	E	F
P	-	-	-	-	-	-

Relay parameter can be pre-set on request.

Measurement ranges $\Delta P$ <sup>1)</sup> others available upon request	100/250/500 Pa 1/2.5/5/10/20 kPa
Margin of error	1 % of max. value
Temperature coefficient span	0.04 % of max. value/K (10..60 °C)
Temperature coefficient zero point	0.05 % of max. value/K (10..60 °C)
Zero point stability	0.5 % of max. value/year
Overload capacity	5 x
Medium	Air, all non-aggressive gases
Max. system pressure	10 kPa for measurement ranges $\leq$ 10 kPa max. nominal pressure of sensor for measurement ranges above 10 kPa
Sensor response time	20 ms
Creep suppression	adjustable 0..10 % of max. value
Operating temperature	10..60 °C
Storage temperature	-10..70 °C
Power consumption	approx. 3 VA
Weight	approx. 0.8 kg
Cable glands	2 x PG 11
Pressure ports	for tubing NW 6 mm
Protection class	IP 65
Certificates	CE, CSA

<sup>1)</sup> Volume flow depending on primary element

Output (root extracted)	A
0..10 V ( $R_L \geq 5 \text{ k}\Omega$ )	1
0..20 mA ( $R_L \leq 500 \Omega$ )	0
4..20 mA ( $R_L \leq 500 \Omega$ )	4

Power supply	B
24 VDC	24D
24 VAC	24A
115 VAC	115
230 VAC	230

Measurement range	C
Measurement range in $\text{m}^3/\text{h}$ , Pa, etc. (e.g. 0..100 $\text{m}^3/\text{h}$ or 0..210 Pa) Maximum value pair ( $\text{m}^3/\text{h} // \text{Pa}$ ) for volume flow measurement	

Time constants	D
none	0
1 s	1
2 s	2
5 s	5

LCD	E
none	0
3 1/2 digit (see foto)	3
4 1/2 digit	4

Order code	A	B	C	D	E
P 82 R / P 82 RM <sup>2)</sup>					

<sup>2)</sup> with optional metal housing

Relay parameter can be pre-set on request.



## Features

- Differential pressure transmitter with root-extracted curve for volume flow applications
- High level of accuracy and long-term stability
- Very little hysteresis; largely independent of temperature
- Easy-to-read display (optional)
- With optional metal housing (P 82 RM)

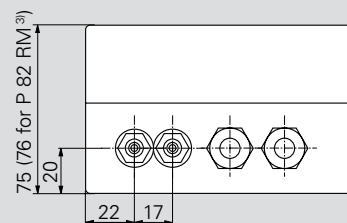
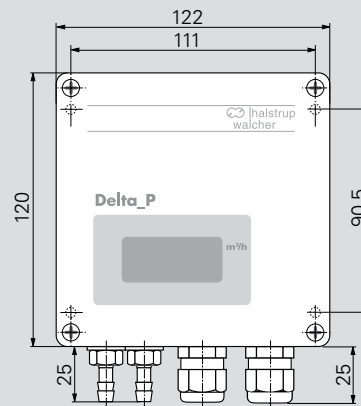

<sup>3)</sup> with optional metal housing

**PLEASE NOTE: The P 82 R has been replaced by the P 26 / P 34!**



## Features

- Compact differential pressure transmitter for basic applications
- Also available with two-wire technology (optional)
- With optional display
- Either with one fixed measurement range or toggling between 4 different measurement ranges
- 4 measurement ranges can be selected via jumpers (optional)
- With  $\pm$  measurement ranges and asymmetric measurement ranges
- With option relay (6 A)
- Suitable for top-hat rail mounting and wall surface installation

PS27 without display

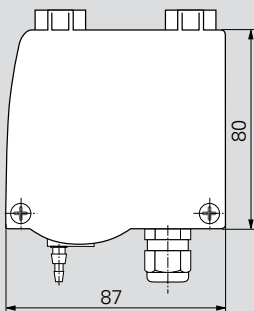

PS27 with display

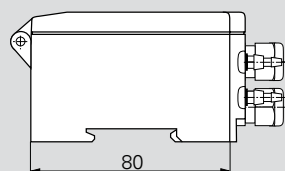
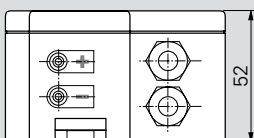
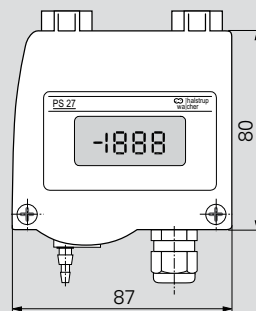

Measurement ranges (also $\pm$ measurement ranges) others available upon request	50/100/200/500 Pa 1/2.5/5/10/20/50/100 kPa
Margin of error	2 % of the set value for $\geq 100$ Pa or 3 % of the set value for 50 Pa
Temperature coefficient span	0.1 % of max. value/K
Temperature coefficient zero point	0.1 % of max. value/K
Overload capacity	12 x for measurement ranges $\leq 20$ kPa 4 x for measurement ranges $\geq 20$ kPa
Medium	Air, all non-aggressive gases
Max. system pressure	10 kPa for measurement ranges $\leq 10$ kPa max. nominal pressure of sensor for measurement ranges above 10 kPa
Sensor response time	20 ms
Time constants	20 ms..4 s adjustable (factory-provided)
Operating temperature	-20..60 °C with Display 0..50 °C
Storage temperature	-20..70 °C
Power consumption	approx. 1 VA
Weight	approx. 0.25 kg
Cable glands	2 x M12
Pressure ports	for tubing NW 4-6 mm
Protection class	IP65
Certificates	CE

Output <sup>1)</sup>	A
0..10 V ( $R_L \geq 50$ k $\Omega$ )	1
2..10 V ( $R_L \geq 50$ k $\Omega$ )	2
0..20 mA ( $R_L \leq 500$ $\Omega$ )	0
4..20 mA ( $R_L \leq 500$ $\Omega$ )	4
0..5 V ( $R_L \geq 50$ k $\Omega$ )	5

<sup>1)</sup> the output signal can be configured using jumpers

Power supply	B
24 VAC/DC (without galvanic separation)	AC/DC
15 .. 32 VDC (two-wire) (only for A = 4)	ZWL

Measurement range	C
Standard (e.g. 0..100 Pa) <sup>2)</sup>	
toggles between: 100/250/500/1 000 Pa	1
toggles between: 250/500/1 000/2 500 Pa	2
toggles between: 1/2.5/5/10 kPa	3
toggles between: 10/25/50/100 kPa	4

<sup>2)</sup> others available upon request

Contact point	D
none	0
1 relay (changeover contacts) max. 230 VAC, 6 A (min. required switching capacity 300 mW) (not for two-wire)	1

LCD	E
none	0
4-digit	1

Order code	A	B	C	D	E
PS27	-	-	-	-	-

Can be pre-set on request:  
Time constant and relay parameter

Measurement ranges others available upon request	50/100/250/500 Pa 1/2.5/5/10/20/50/100 kPa
Margin of error (0.3 Pa margin of error for the reference)	0.5 % of max. value, min. 0.3 Pa or 1 % of max. value
Temperature coefficient span	0.04 % of max. value/K (10 .. 60 °C)
Temperature coefficient zero point	±0 % (cyclical zero-point correction)
Overload capacity	200 x for measurement ranges < 2.5 kPa 600 kPa for measurement ranges ≥ 2.5 kPa
Medium	Air, all non-aggressive gases
Max. system pressure	10 kPa for measurement ranges ≤ 10 kPa Max. nominal pressure of sensor for measurement ranges above 10 kPa
Sensor response time	20 ms
Display	4 ½ digit
Time constants	adjustable up to 10 s
Operating temperature	10 .. 60 °C
Storage temperature	-10 .. 70 °C
Power consumption	approx. 5 VA
Weight	approx. 0.8 kg
Pressure ports	for tubing NW 6 mm
Protection class	IP 50 (installed)
Certificates	CE

Output	A
0 .. 10 V ( $R_L \geq 2 \text{ k}\Omega$ )	1
± 5 V ( $R_L \geq 2 \text{ k}\Omega$ )	5
0 .. 20 mA ( $R_L \leq 500 \Omega$ )	0
4 .. 20 mA ( $R_L \leq 500 \Omega$ )	4

Measurement range	B
Measurement range (e.g. 0 .. 100 Pa, -10 .. 40 mbar, 0 .. 200 mmHg etc.)	

Margin of error	C
0.5 % of max. value, min. 0.3 Pa	05
1 % of max. value (standard)	1

Power supply	D
24 VDC, +20 % / -15 %	24D
24 VAC, +6 % / -15 % (50/60 Hz) (with galvanic separation)	24A
115 VAC, +6 % / -15 % (50/60 Hz)	115
230 VAC, +6 % / -15 % (50/60 Hz)	230

Contact points	E
2 relays with floating changeover contacts 230 VAC (50/60 Hz), 6 A	R
2 transistors with open collector $U_{CE} \leq 50 \text{ V}$ ; $I_C \leq 200 \text{ mA}$ , floating	T

Order code	A	B	C	D	E
REG 21	-	-	-	-	-

Can be pre-set on request:  
Time constant, relay parameter,  
deactivation of the cyclic zeroing



## Features

- Pressure measurement and regulation in a device
- Accurate measurement of differential pressure with automatic zero-point calibration and high overload protection
- Switching outputs can be used as 2-point regulator (pressure switch), for activating/deactivating a final control element (e.g. pump), with relay hysteresis
- Switching outputs can be used as a 3-point regulator (e.g. ON 1 - OFF - ON 2) for activating/deactivating two final control elements, (e.g. air intake/outflow fans), with relay hysteresis
- Asymmetry also possible, e.g. -10 .. 40 mbar
- Housing: control panel housing (installed)

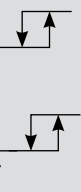

## Panel housing / control panel installation

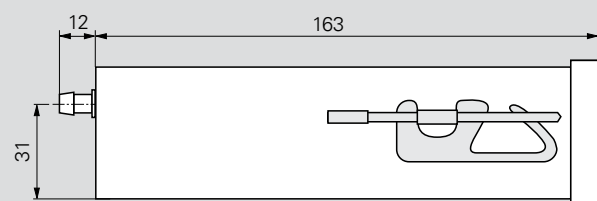
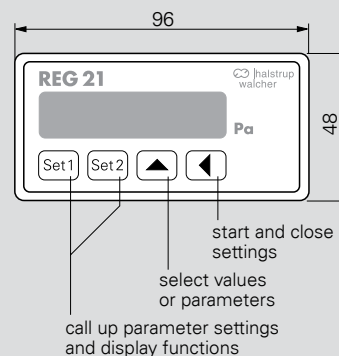

halstrup-walcher GmbH  
Stegener Str. 10  
79199 Kirchzarten  
Germany

Tel. + 49 (0) 76 61 39 63-0  
Fax + 49 (0) 76 61 39 63-99  
www.halstrup-walcher.com  
info@halstrup-walcher.de



#### **Australia / New Zealand**

Bestech Australia Pty, Ltd.  
Unit 14, 44 Garden Blvd,  
Dingley, VIC 3172  
Australia  
Tel. +61 (0) 3 9540 5100  
Fax +61 (0) 3 9551 5541  
Enquiry@bestech.com.au  
www.bestech.com.au

#### **Belgium / Luxembourg / Netherlands**

DIMED nv  
Joe Englishstraat 47  
2140 Antwerpen  
Belgium  
Tel. +32 3 236 64 65  
Fax +32 3 236 64 62  
info@dimed.be  
www.dimed.eu

#### **China**

Shanghai Yu Ting  
Scientific Co., LTD  
BeiGuan Village, MaLu Town,  
JiaDing District,  
Shanghai City, PRC  
Tel. +86 21 6915 3366  
Tel. +86 21 6915 5916  
Fax +86 21 6915 3939  
ch-sys@ch-sys.net  
www.ch-sys.com

#### **Denmark**

Hans Buch A/S  
Roskildevej 8-10  
2620 Albertslund  
Tel. +45 43 68 50 00  
Fax: +45 43 68 50 50  
info@hansbuch.dk  
www.hansbuch.dk

#### **Italy**

FISME srl  
Via Volta 21  
20082 Binasco (MI)  
Tel. +39 02 905 53 58  
Fax +39 02 905 22 67  
fisme@tin.it  
www.fisme.it

#### **Japan**

Krone Corporation  
2-22-1 Higashi-Shinkoiwa  
Katsushika-ku  
J-Tokyo 1240023  
Tel. +81 (0) 3 3695 5431  
Fax: +81 (0) 3 3695 5698  
sales-tokyo@krone.co.jp  
www.krone.co.jp

#### **Austria / Croatia / Serbia / Hungary / Slovenia**

Industrie Automation Graz  
Ing. W. Häusler GmbH  
Autaler Str. 55  
8074 Raaba  
Austria  
Tel. +43 (0) 316 405 105  
Fax +43 (0) 316 405 105-22  
office@iag.co.at  
www.iag.co.at

#### **Sweden**

DJ Stork Automation AB  
Karlsbodavägen 39  
16867 Bromma  
Tel. +46 (0) 8 635 60 30  
Fax +46 (0) 8 635 60 31  
stork@storkautomation.se  
www.storkautomation.se

#### **Switzerland**

Swissfilter AG  
Gewerbestrasse 3  
5037 Muhen  
Tel. +41 (0) 62 737 54 80  
Fax +41 (0) 62 737 54 81  
info@swissfilter.ch  
www.swissfilter.ch

#### **Turkey**

CAGDAS Automation  
& Engineering Co. Ltd.  
Kizilay cad. 28006 sok No: 5  
01010 Seyhan / Adana  
Tel. +90 322 359 81 85  
Fax +90 322 359 36 39  
cagdas@cagdasltd.com.tr  
www.cagdasltd.com.tr

#### **Taiwan (R.O.C.)**

Chih Horng Scientific Co., Ltd.  
6F, No.69-5, Sec. 2,  
Zhongzheng E. Rd.,  
Tamsui Dist.,  
New Taipei City 251  
Tel. +886 (02) 2808 0169  
Fax +886 (02) 2808 0176  
chih.mail@msa.hinet.net  
www.ch-sys.com

#### **USA**

Intelligent Measurement Solutions LLC  
7801 Clinton-Macon Road  
49236 Clinton, MI  
Tel. +1 (616) 608 7919  
Tel. +1 (734) 637-1596  
Fax +1 (616) 608 7954  
darrell@i-m-solutions.net  
www.h-wusa.com