

**NEW RANGE FOR 2015**

*THE*  
**BRUNDLELINE**  
*COLLECTION*

F.H.BRUNDLER GATE AUTOMATION & INTERCOM SYSTEMS

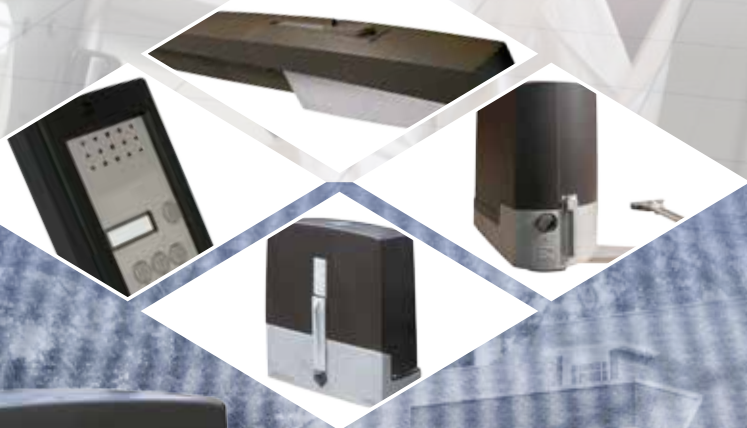

**F.H.BRUNDLER**  
SERVING THE TRADE SINCE 1889

POWERED BY  
**CAME**



# F.H.BRUNDLÉ

SERVING THE TRADE SINCE 1889



Frederick Henry Brundle

Having served his apprenticeship as an ironmonger in Canterbury, young Frederick Henry Brundle moved to London to work for a company supplying the tea trade.

It was not long before he spotted an opportunity and, with a loan from his father, set up a business supplying nails and ironmongery to the booming packing case industry. He also added to his range, horse shoes and farrier's sundries. Throughout London, the name of F.H.Brundle became synonymous with quality and competitive prices.

As trade has changed over the years, F.H.Brundle has adapted to meet the needs of their customers. When business moved outwards from London, branches were set up to serve customers further afield with an ever-widening stock range.

As you will see from this catalogue we actually stock a huge range which we offer at consistently kept prices. Our depots are geared to respond quickly, each holding large stocks and operating a fleet of vehicles to provide a fast, personal service.

Our business is now run by Richard Brundle, the fourth generation and his son Michael. We are certain that we will be providing our customers with a quality service for many years to come.



Michael Brundle and Richard Brundle M.B.E.



**GLASGOW**  
 Tel: 0141 332 3231  
 Fax: 0141 332 7325  
 Email: glasgow@brundle.com

**EDINBURGH**  
 Tel: 0131 335 5999  
 Fax: 0131 335 5911  
 Email: edinburgh@brundle.com

**ST HELENS**  
 Tel: 01942 86 88 88  
 Fax: 01942 86 88 99  
 Email: haydock@brundle.com

**ILKESTON**  
 Tel: 0115 930 2070  
 Fax: 0115 951 2455  
 Email: ilkeston@brundle.com

**BIRMINGHAM**  
 Tel: 0121 565 8282  
 Fax: 0121 565 8292  
 Email: birmingham@brundle.com



**LONDON**  
 Tel: 01708 25 35 45  
 Fax: 01708 25 35 50  
 Email: sales@brundle.com

**SOUTHAMPTON**  
 Tel: 023 8070 3333  
 Fax: 023 8070 5555  
 Email: southampton@brundle.com

**HUGE STOCKS - NATIONWIDE SERVICE – KEEN PRICES**

## BRUNDLELINE

THE NEW GATE AUTOMATION RANGE FROM F.H.BRUNDLÉ



### BRUNDLEDRIIVE

#### SWING GATE AUTOMATION

Non-reversing gear motor with decoder for swing gates with leaves up to 2.2m long. Aluminium and ABS cover, worm screw based reduction system, crown and conical torque.

This gear motor is designed to power swing gates in apartment blocks and homes.

**SEE PAGE 4**



### BRUNDLÉREACH

#### SWING GATE AUTOMATION

Operator complete with control board, movement control and obstruction detecting device plus mechanical endstops for swing gates with leaves up to 2m.

This operator is designed to power swing gates for residential and apartment block use.

**SEE PAGE 6**



### BRUNDLESIDE

#### SLIDING GATE AUTOMATION

Operator complete with electronic movement control and obstruction detecting device, plus mechanical endstops for sliding gates of up to 400kg and 10m in length.

This operator is designed to power sliding gates in residential and apartment block settings.

**SEE PAGE 8**

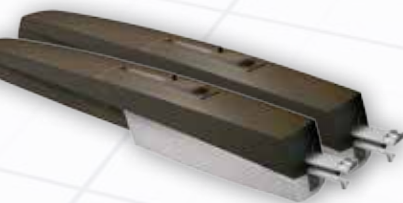

## SAFETY STANDARDS



It is the duty of the Machine manufacturer/installer to ensure that the system is fitted in compliance with the current Euro Normatives EN12453, EN12445 and in accordance with Machinery Directive 2006/42/EC in order that it will not endanger any exposed persons. To that end the Machine manufacturer/installer must CE mark the gate system to be in compliance with the above directive and provide the end user with documentary evidence of this by way of a written CE declaration. It is the responsibility of the end user to ensure that their gate system is maintained on a regular basis and that all safety devices are checked for efficacy.



## SWING GATE AUTOMATION



### CODE: 21UOPP6000

Non-reversing gear motor with decoder for swing gates with leaves up to 2.2m long. Aluminium and ABS cover, worm screw based reduction system, crown and conical torque.

This gear motor is designed to power swing gates in apartment blocks and homes.

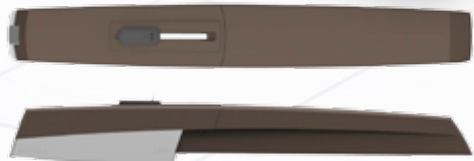

### COMPLETE KIT INCLUDES:

- 2 x Worm Drive Motors
- 1 x Flashing Light
- 1 x Pair Safety Beams
- 2 x Remote Control
- 1 x Control Panel

**ONLY  
£325.00**



**BRUNDLELINE**  
POWERED BY  
**CAME** **2** YEAR WARRANTY

## DIMENSIONS

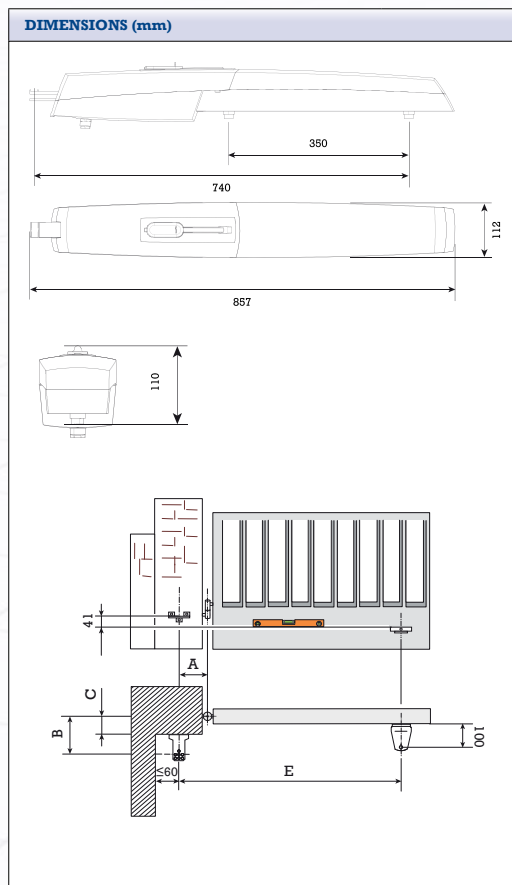

## TECHNICAL FEATURES

| TYPE                                      | 21UOPP6000 |
|-------------------------------------------|------------|
| Protection rating (IP)                    | 44         |
| Control panel power supply (V - 50/60 Hz) | 230 AC     |
| Power supply motor (V)                    | 24 DC      |
| Max. draw (A)                             | 5          |
| Max. power (W)                            | 120        |
| Duty cycle (%)                            | 50         |
| Opening time at 90° (s)                   | 19         |
| Operating temperature (°C)                | -20 ÷ +55  |
| Insulation class                          | 3          |
| Reduction ratio (i)                       | 1/36       |
| Thrust (N)                                | 400 ÷ 2000 |
| Weight (kg)                               | 6.1 *      |

\* The weight of the motor includes the brackets. The motor alone weighs 4.6kg.

## LIMITS TO USE

| TYPE                       | 21UOPP6000 |     |     |
|----------------------------|------------|-----|-----|
| Max. gate leaf length (m)  | 1.0        | 1.7 | 2.2 |
| Max. gate leaf weight (kg) | 250        | 225 | 200 |

## APPLICATION SIZE (mm)

| OPENING (°) | A   | B         | C      | E   |
|-------------|-----|-----------|--------|-----|
| 90          | 130 | 110 ÷ 170 | 0 ÷ 60 | 740 |
| 115         | 150 | 110 ÷ 160 | 0 ÷ 50 | 740 |

## ACCESSORIES

### SAFETY BEAMS

Pair of Brundleline safety beams.



**CODE:** 21DNF10  
**PRICE:** £23.00

### FLASHING LIGHT

Brundleline flashing light.



**CODE:** 21LP24  
**PRICE:** £21.00

### REMOTE CONTROL

Brundleline remote control.



**CODE:** 21ATP864  
**PRICE:** £17.00

This equipment needs to be installed in accordance with EN12453, and in compliance with Machinery Directive 2006/42/EC



## SWING GATE AUTOMATION



### CODE: 21UOPB1000

Operator complete with control board, movement control and obstruction detecting device plus mechanical endstops for swing gates with leaves up to 2m.

This operator is designed to power swing gates for residential and apartment block use.



### COMPLETE KIT INCLUDES:

- 2 x Articulated Arm Motors
- 1 x Flashing Light
- 1 x Pair Safety Beams
- 2 x Remote Control
- 1 x Frequency Card

**ONLY  
£399.00**



**BRUNDLELINE**  
POWERED BY  
**CAME** **2**  
YEAR WARRANTY

## DIMENSIONS

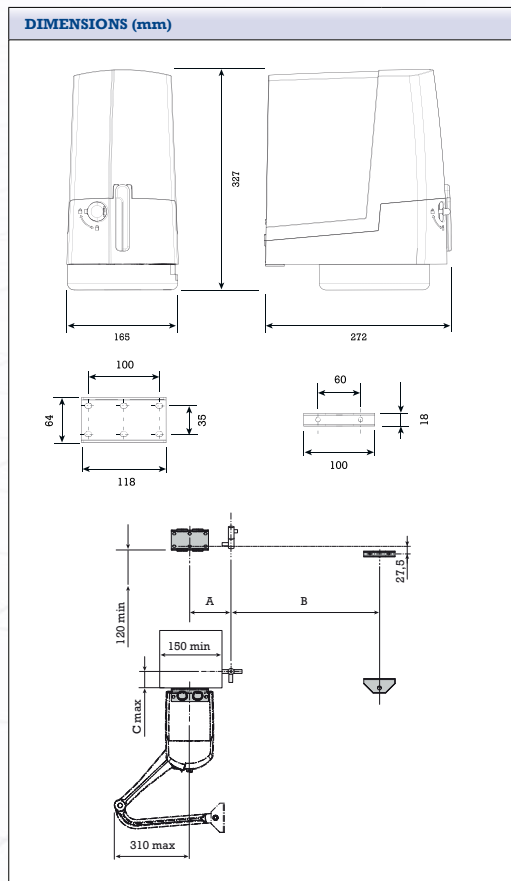

## TECHNICAL FEATURES

| TYPE                        | 21UOPB1000 |
|-----------------------------|------------|
| Protection rating (IP)      | 44         |
| Power supply (V - 50/60 Hz) | 230 AC     |
| Power supply motor (V)      | 24 DC      |
| Max. draw (A)               | 4          |
| Stand-by consumption (W)    | 7          |
| Consumption with GPI (W)    | 1.15       |
| Max. power (W)              | 140        |
| Duty cycle (%)              | 50         |
| Operating temperature (°C)  | -20 ÷ +55  |
| Insulation class            | I          |
| Opening time at 90° (s)     | 19 ÷ 25    |
| Reduction ratio (i)         | 1 / 1680   |
| Thrust (N)                  | 150        |
| Weight (kg)                 | 10.5       |

## LIMITS TO USE

| TYPE                       | 21UOPB1000 |     |     |
|----------------------------|------------|-----|-----|
| Max. gate leaf length (m)  | 1.0        | 1.7 | 2.2 |
| Max. gate leaf weight (kg) | 250        | 225 | 200 |

## APPLICATION SIZE (mm)

| OPENING (°) | A       | B   | C - MAX. |
|-------------|---------|-----|----------|
| 90          | 140     | 420 | 150      |
| 90          | 160÷180 | 380 | 150      |
| 110         | 200÷220 | 400 | 50       |

## ACCESSORIES

### SAFETY BEAMS

Pair of Brundline safety beams.



CODE: 21DNF10

PRICE: £23.00

### FLASHING LIGHT

Brundline flashing light.



CODE: 21LP24

PRICE: £21.00

### REMOTE CONTROL

Brundline remote control.



CODE: 21ATP864

PRICE: £17.00

This equipment needs to be installed in accordance with EN12453, and in compliance with Machinery Directive 2006/42/EC



## SLIDING GATE AUTOMATION



**CODE: 21UOPS2000**

Operator complete with electronic movement control and obstruction detecting device, plus mechanical endstops for sliding gates of up to 400kg and 10m in length.

This operator is designed to power sliding gates in residential and apartment block settings.



**COMPLETE KIT INCLUDES:**

- 1 x Sliding Motor
- 1 x Flashing Light
- 1 x Pair Safety Beams
- 2 x Remote Control
- 1 x Frequency Card

**ONLY  
£299.00**



**BRUNDLELINE**  
POWERED BY  
**CAME** **2**  
YEAR WARRANTY



## DIMENSIONS

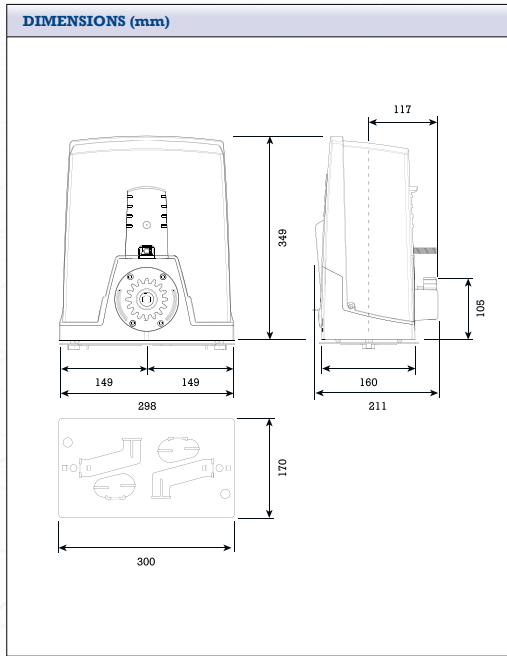

## TECHNICAL FEATURES

| TYPE                             | 21UOPS2000 |
|----------------------------------|------------|
| Protection rating (IP)           | 44         |
| Power supply (V - 50/60 Hz)      | 230 AC     |
| Motor power supply (V)           | 24 DC      |
| Max. draw (A)                    | 7          |
| Standby consumption (W)          | 7.4        |
| Consumption with Green Power (W) | 1.2        |
| Max. power (W)                   | 150        |
| Duty cycle (%)                   | 50         |
| Operating temperature (°C)       | -20 + +55  |
| Insulation class                 | I          |
| Weight (kg)                      | -          |

## LIMITS TO USE

| TYPE                       | 21UOPS2000 |
|----------------------------|------------|
| Max. gate leaf length (m)  | 10         |
| Max. gate leaf weight (kg) | 400        |

## ACCESSORIES

### SAFETY BEAMS

Pair of Brundleline safety beams.



**CODE:** 21DNF10  
**PRICE:** £23.00

### FLASHING LIGHT

Brundleline flashing light.



**CODE:** 21LP24  
**PRICE:** £21.00

### REMOTE CONTROL

Brundleline remote control.



**CODE:** 21ATP864  
**PRICE:** £17.00

This equipment needs to be installed in accordance with EN12453, and in compliance with Machinery Directive 2006/42/EC



# INTERCOM SYSTEMS

## GSM ENTRY INTERCOMS



The new GSM range from BPT is a telephone based door entry solution. Using GSM mobile or landline technology, this system is designed for applications where a hard wired door entry system cannot be installed.

### Example System Setup

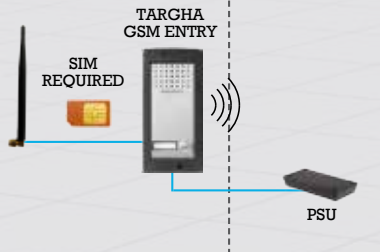

1 gateway to 1 house GSM Entry intercom kit including Targha GSM panel.

**COMPLETE KIT INCLUDES:**  
1 x Entry Panel  
1 x PSU  
1 x Antenna

**CODE: 21TAGSM/1**  
**PRICE: £440.00**



1 gateway to 2 house GSM Entry intercom kit including Targha GSM panel.

**COMPLETE KIT INCLUDES:**  
1 x Entry Panel  
1 x PSU  
1 x Antenna

**CODE: 21TAGSM/2**  
**PRICE: £460.00**



1 gateway to 4 house GSM Entry intercom kit including Targha GSM panel.

**COMPLETE KIT INCLUDES:**  
1 x Entry Panel  
1 x PSU  
1 x Antenna

**CODE: 21TAGSM/4**  
**PRICE: £534.00**



1 gateway to 1 house GSM Entry intercom kit including Targha GSM keypad panel.

**COMPLETE KIT INCLUDES:**  
1 x Entry Panel  
1 x PSU  
1 x Antenna

**CODE: 21TAKGSM/1**  
**PRICE: £544.00**

**CALL F.H.BRUNDLÉ TO DISCUSS YOUR REQUIREMENTS**

## VANDAL RESISTANT GSM PLUS+ INTERCOMS

The new GSM range from BPT is a telephone based door entry solution. Using GSM mobile or landline technology, this system is designed for applications where a hard wired door entry system cannot be installed. The GSM entry panel range includes versions of all BPT entry panels as well as VR and brass panels manufactured in the UK to the highest standards. Bespoke units can also be produced to suit every requirement.



1 gateway to 1 house GSM Plus+ intercom kit including Vandal Resistant GSM Plus+ panel.



**COMPLETE KIT INCLUDES:**  
 1 x Entry Panel  
 1 x PSU  
 1 x Control Unit  
 1 x Antenna

**CODE: 21VRGSM/1**  
**PRICE: £467.00**

1 gateway to 1 house GSM Plus+ intercom kit including Satin Black GSM Plus+ panel.



**COMPLETE KIT INCLUDES:**  
 1 x Entry Panel  
 1 x PSU  
 1 x Control Unit  
 1 x Antenna

**CODE: 21BLGSM/1**  
**PRICE: £484.00**

1 gateway to 1 house GSM Plus+ intercom kit including Vandal Resistant with keypad GSM Plus+ panel.



**COMPLETE KIT INCLUDES:**  
 1 x Entry Panel  
 1 x PSU  
 1 x Control Unit  
 1 x Antenna

**CODE: 21VRKSGM/1**  
**PRICE: £596.00**

1 gateway to 1 house GSM Plus+ intercom kit including Satin Black with keypad GSM Plus+ panel.



**COMPLETE KIT INCLUDES:**  
 1 x Entry Panel  
 1 x PSU  
 1 x Control Unit  
 1 x Antenna

**CODE: 21BLKSGM/1**  
**PRICE: £613.00**

### PANEL DIMENSIONS

| BUTTON/KEYPAD                           | DIMENSIONS             |
|-----------------------------------------|------------------------|
| 1 Button                                | H 175 x W 100 x D 40mm |
| 1 Button with Keypad and 2 Button       | H 225 x W 100 x D 45mm |
| 3 and 4 Button (with or without keypad) | H 295 x W 100 x D 45mm |

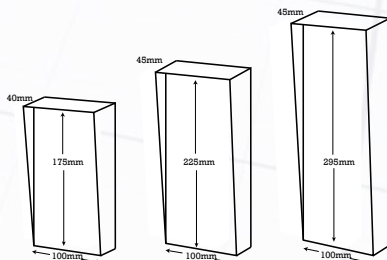



## AUDIO INTERCOMS

We offer a wide range of audio intercoms from BPT with a whole host of entry panels and handset/receivers. These come in easy-to-order off-the-shelf kits with a single code based on the system you require.



1 button Targha audio door entry panel to standard Agata audio handset.

**COMPLETE KIT INCLUDES:**

- 1 x 1 Button Panel
- 1 x Agata Handset
- 1 x PSU

**CODE: 21TAAG/1**

**PRICE: £64.00**

1 button Targha audio door entry panel with keypad to standard Agata audio handset.



**COMPLETE KIT INCLUDES:**

- 1 x 1 Button Panel with Keypad
- 1 x Agata Handset
- 1 x PSU

**CODE: 21TAKAG/1**

**PRICE: £175.00**

2 button Targha audio door entry panel to 2 standard Agata audio handsets.



**COMPLETE KIT INCLUDES:**

- 1 x 2 Button Panel
- 2 x Agata Handset
- 1 x PSU

**CODE: 21TAAG/2**

**PRICE: £75.00**

2 button Targha audio door entry panel with keypad to 2 standard Agata audio handsets.



**COMPLETE KIT INCLUDES:**

- 1 x 2 Button Panel with Keypad
- 2 x Agata Handset
- 1 x PSU

**CODE: 21TAKAG/2**

**PRICE: £181.00**

## VIDEO INTERCOMS

We offer a wide range of video intercoms from BPT with a whole host of entry panels and monitors. These come in easy-to-order off-the-shelf kits with a single code based on the system you require.

1 button Thangram video door entry panel to Perla colour video monitor.



NB: Perla monitor is also available in black (Code: 21THPBV1)

**COMPLETE KIT INCLUDES:**

- 1 x 1 Button Panel
- 1 x Perla Monitor
- 1 x PSU
- 1 x Relay

**CODE: 21THPWV/1**

**PRICE: £735.00**

1 button Lithos video door entry panel to Perla colour video monitor.



NB: Perla monitor is also available in black (Code: 21LIPBV1)

**COMPLETE KIT INCLUDES:**

- 1 x 1 Button Panel
- 1 x Perla Monitor
- 1 x PSU
- 1 x Relay

**CODE: 21LIPWV/1**

**PRICE: £530.00**

1 button Lithos video door entry panel to Agata colour video monitor.



**COMPLETE KIT INCLUDES:**

- 1 x 1 Button Panel
- 1 x Agata Monitor
- 1 x PSU
- 1 x Relay

**CODE: 21LIAGCV/1**

**PRICE: £436.00**

1 button Thangram video door entry panel with keypad to Agata colour video monitor.



**COMPLETE KIT INCLUDES:**

- 1 x 1 Button Panel with Keypad
- 1 x Agata Monitor
- 1 x PSU
- 1 x Relay

**CODE: 21THKAGCV/1**

**PRICE: £851.00**

**PERLA MONITOR**

**TARGHA ENTRY PANEL**

**3 YEAR WARRANTY AS STANDARD**

## FREE TRAINING COURSES

F.H.Brundle now offer customers the opportunity to attend **FREE** automation training courses held at **CAME training centres** in Nottingham, Manchester, Hemel Hempstead & Dublin.

A range of courses are available to suit different levels of experience, from newcomers to the automation industry through to experienced installers.

**CAME** Training courses not only cover the technical aspects of the products but include all aspects of the installation process, setup and safety standards.



## FOUNDATION LEVEL

1 DAY COURSE

The Foundation course starts with an introduction to gate automation and follows on by briefly introducing some of the most commonly used products to the audience. This is ideal for those who are new to this industry.

Along with a general introduction to gate automation, you will find out about installation characteristics, types of motors and safety requirements. The course provides you with the knowledge to specify and quote with confidence for any forthcoming business. With the basic range of 230 and 24 volt **CAME** gate automation systems covered, you will leave the training course fully prepared to undertake your first installation of **CAME** equipment.

## ADVANCED LEVEL

1 DAY COURSE

The Advanced course focuses more on the technical aspects of **CAME** products but continues to include installation concepts and solutions.

If you, or any of your engineers, have industry experience or are looking to increase the understanding of **CAME** automation systems then this course is for you.

The course covers both 230 volt and 24 volt LCD control panels and the many configurable options and features available. It also covers the **CAME** sliding gate range of products (and their capabilities) and affords the opportunity for real practical experience on full size working gate models.

Download technical information & installation guides from our website:

# [www.fhbrundle.co.uk](http://www.fhbrundle.co.uk)

## EN SAFETY TRAINING COURSES

The automatic gate, barrier and entrance way industry in the UK is becoming increasingly concerned with safety and for very good reason. Numerous unfortunate, avoidable accidents have made headlines in recent years.

Understandably, everyone in the industry wants to ensure that their installations are not only safe, but also meet the standards required by UK and European law.

Guidelines drawn up for the sector are not black and white. Interpretation is difficult, leading to manufacturers and installers of automation equipment wrestling to understand their responsibilities. **CAME** are proactive in their approach to this problem.

F.H.Brundle can now offer customers the opportunity to attend specific safety training courses held at **CAME training centres** in Nottingham, Manchester, Hemel Hempstead or Dublin.

Delegates will receive a comprehensive guide through the maze of UK European laws and standards applicable to the gate automation industry. This includes advice and solutions for eliminating risks during and after installation as well as steps to becoming compliant.

(This course attracts a fee)

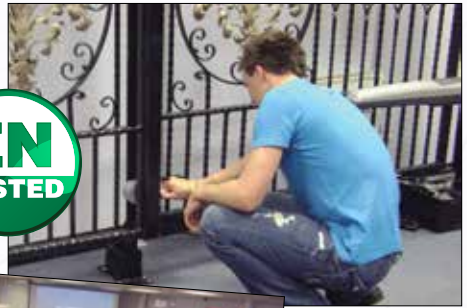

## BOOK YOUR TRAINING NOW

- Ask about training at your local branch
- Email [cametraining@brundle.com](mailto:cametraining@brundle.com) to book your place now.

[fhbrundle.co.uk/cametraining](http://fhbrundle.co.uk/cametraining)





**WROUGHT IRON COMPONENTS**



**PRO-RAILING**



**TUBE CLAMPS**



**GATE AUTOMATION**



**STEEL**



**MESH**

**IF YOU WOULD LIKE TO RECEIVE A COPY OF ANY OF OUR CATALOGUES, PLEASE CONTACT ONE OF THE BRANCHES FROM THE LIST BELOW.**

- TOP QUALITY PRODUCTS
- FRIENDLY, RELIABLE SERVICE
- NATIONWIDE DELIVERY
- CONSISTENTLY KEEN PRICES
- THE MOST COMPREHENSIVE RANGE OF PRODUCTS FROM ONE SUPPLIER
- ON-LINE ORDERING 24/7

09/2015

**Please phone your nearest branch for further details**

502 Millbrook Road  
Third Avenue  
Millbrook  
Southampton  
Hants SO15 0JX

Lamson Road  
Ferry Lane North  
Rainham  
Essex  
RM13 9YY

Condor Road  
Quarry Hill Ind. Est  
Ilkeston  
Derbyshire  
DE7 4RE

81-82 Middlemore Ind. Est  
Middlemore Road  
Smethwick  
Birmingham  
B66 2EP

Haydock Lane  
Haydock Ind. Est  
St. Helens  
Merseyside  
WA11 9XE

Huly Hill Road  
Edinburgh Interchange  
Newbridge  
Edinburgh  
EH28 8PH

28 Coxhill Street  
Port Dundas  
Springburn  
Glasgow  
G21 1HN

Tel: 023 8070 3333  
Fax: 023 8070 5555

Tel: 01708 25 35 45  
Fax: 01708 25 35 50

Tel: 0115 930 2070  
Fax: 0115 951 2455

Tel: 0121 565 8282  
Fax: 0121 565 8292

Tel: 01942 86 88 88  
Fax: 01942 86 88 99

Tel: 0131 335 5999  
Fax: 0131 335 5911

Tel: 0141 332 3231  
Fax: 0141 332 7325

**Web: [www.fhbrundle.co.uk](http://www.fhbrundle.co.uk)**

**Email: [sales@brundle.com](mailto:sales@brundle.com)**