

Protective Packaging

At Plastics by Design we design, develop and produce all our protective packaging with the highest standards, delivering the best quality packaging to our customers.

We have a comprehensive customer service to target the best price, design, unique solutions, product loading and transportation for every client's project.

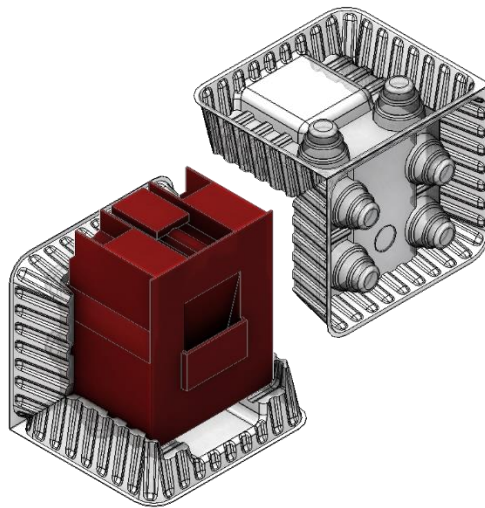

We have a vast product range to choose from and if we don't already have the perfect forming we design and sample for free!

A great advantage in plastic packaging compared to cardboard packaging is the assembling. Plastic packaging needs no assembling time or work. It also can be various colours, textures and shapes, making the packaging more suitable to the actual product. The packaging can also be recycled!

The process is simple and quick; our first step is creating designs that have come from the customer's spec/idea. We then make samples to show the customer so they can add their own critique. Engineering, prototyping and further developments all lead to the final step of production. We then produce the perfect package and deliver to our customer in global reach.

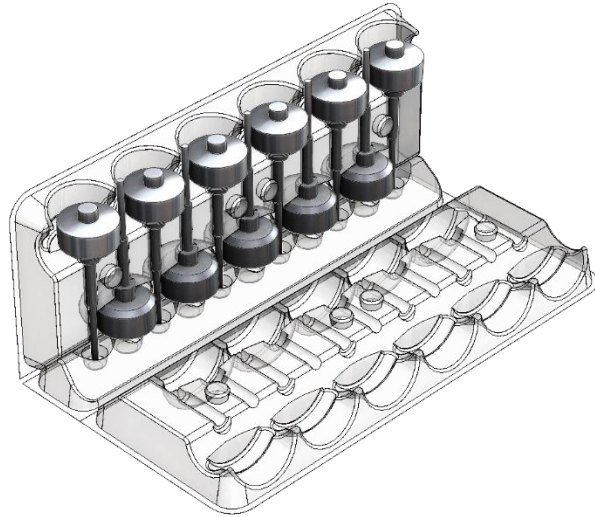

The most important element to protect packaging is the safety of the product. Our protective packaging is highly specialised using the best drop testing machines. We make sure every product is dropped tested to the legal specification and requirements. We do this in order to keep the item safe from any damage through transportation. With our expert team of designers, we know how to design and produce a plastic package that will enhance the products stability from being distorted. For example, using crumple zones that will allow for shock absorption. The tests allow us to check that your product will remain safe in the packaging through all types of transit. We can do this with various techniques that we have learnt through the 35 plus years of work we've done in vacuum forming.

